



GROUP
Safety Recall Campaign

NUMBER
SC176 (Rev 4, 07/13/2023)

MODEL
**2012-2016MY
Soul (AM, PS)**

DATE
April 2019

SAFETY RECALL CAMPAIGN

SUBJECT: ENGINE CONTROL UNIT (ECU)
LOGIC IMPROVEMENT (SC176)

* NOTICE

This bulletin has been revised to include additional information. New/revised sections of this bulletin are indicated by a black bar in the margin area.

This bulletin provides the procedure to upgrade the Catalyst Overheating Protection (COP) logic in the Engine Control Unit (ECU) and, if necessary, replace the Catalytic Converter on some 2012 ~ 2016 MY Soul (AM/PS) vehicles, produced from July 8, 2011 through August 11, 2016. Depending on the extent of damage, the short block assembly may also need to be replaced. The affected vehicles may exhibit catalyst system efficiency deterioration or a malfunction indicator lamp illumination with an **active, history** or **pending DTC P0420** (Catalyst System Efficiency Below Threshold Bank 1). Under certain conditions, the catalytic converter may become damaged due to overheating caused by an excessive increase of exhaust gas temperatures. If the catalytic converter is damaged, substrate particles can enter the engine combustion chamber and cause abnormal engine combustion. Continuous abnormal engine combustion can result in damage to one or more of the engine's pistons which can cause piston rod breakage, potentially puncturing the engine block allowing engine oil to escape. Engine oil that contacts a hot exhaust surface may result in a fire. Before conducting the procedure, verify the vehicle is included in the list of affected VINs.

* NOTICE

There is no charge to the vehicle owner for this repair. Under applicable law, you may not sell or otherwise deliver any affected new vehicle until it has been repaired pursuant to the procedures set forth in this bulletin.

* NOTICE

To assure complete customer satisfaction, always remember to refer to KDealer+ Warranty Coverage (validation) Inquiry Screen (Service → Warranty Coverage → Warranty Coverage Inquiry) for a list of any additional campaigns that may need to be performed on the vehicle before returning it to the customer.

* IMPORTANT

For any other failure not related to MIL ON with DTCs P0420 and P030X, perform diagnostic and repair according to normal service procedures.

File Under: <Safety Recall Campaign>

Circulate To: General Manager Service Manager Parts Manager
 Service Advisors Technicians Body Shop Manager Fleet Repair

Inspection Procedure:

- Using the KDS (connected to the internet to create and transmit a VDN*), perform a Fault Code Search and confirm DTC P0420 or both P0420 and P030X is/are **stored (Active, History or Pending)**. Follow the flow chart below and perform the necessary procedure(s).
 *A Vehicle Diagnosis Number (VDN) must be created with DTC P0420 or P0420 and P030X, prior to ordering select parts and performing necessary procedure(s) according to flow chart. If a VDN is not created, Parts order entry or Warranty claim submission issues may occur.

Flow Chart:

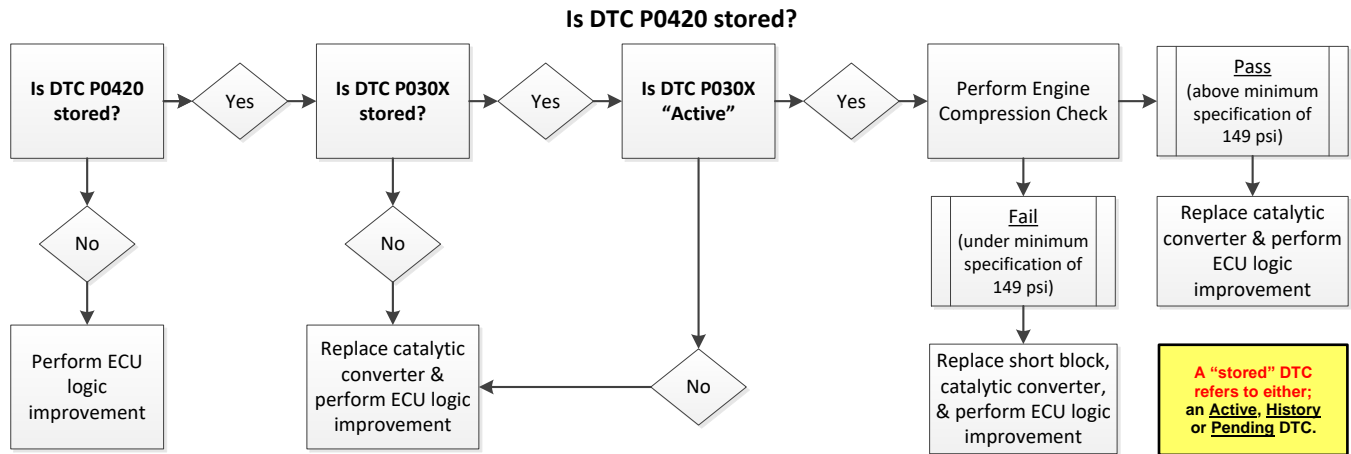

Contents:

ECU Upgrade Procedure:..... Pages 2-8
Engine Compression Check Procedure:..... Page 9
Catalytic Converter Assembly Replacement Procedure: Page 9
Short Block Replacement Procedure:..... Pages10

ECU Upgrade Procedure:

To correct this condition, the ECU should be reprogrammed using the KDS download, as described in this bulletin.

Upgrade Event Name
412. PS GAMMA 1.6GDI ECU MIL ON DTC (P0420) LOGIC IMPROVEMENT
413. AM GAMMA 1.6GDI ECU MIL ON DTC (P0420) LOGIC IMPROVEMENT

★ NOTICE

- A fully charged battery is necessary before ECU upgrade can take place. It is recommended that the Midtronics GR8-1299 system be used in ECU mode during charging. **DO NOT** connect any other battery charger to the vehicle during ECU upgrade.
- All ECU upgrades must be done with the ignition key in the 'ON' position.
- Be careful not to disconnect the VCI-II connected to the vehicle during the ECU upgrade procedure.
- **DO NOT** start the engine during ECU upgrade.
- **DO NOT** turn the ignition key 'OFF' or interrupt the power supply during ECU upgrade.
- When the ECU upgrade is completed, turn the ignition 'OFF' and wait 10 seconds before starting the engine.
- **ONLY** use approved ECU upgrade software designated for the correct model, year.

★ NOTICE

Before attempting an ECU upgrade on any Kia model, make sure to first determine whether the particular model is equipped with an immobilizer security system. Failure to follow proper procedures may cause the PCM to become inoperative after the upgrade and any claims associated with this repair may be subject to chargeback.

SUBJECT: ENGINE CONTROL UNIT (ECU) LOGIC IMPROVEMENT (SC176)
ROM ID INFORMATION TABLE:
Upgrade Event #412 (PS) & 413 (AM)

Model	EM	TM	IMMO	ECU P/No.	ECU ROM ID	
					Previous	New
12-13MY Soul (AM)	1.6 ULEV	MT	No	39110-2BCG0 39110-2BCJ0	GGAM-BNU6ES00600 GGAM-BNU6ES01600 GGAM-BNU6ES02600 GGAM-BNU6ES03600 GGAM-BNU6ES04600 GGAM-BNU6ES05600 GGAM-BNU6ES06600 GGAM-BNU6ES07600 GGAM-BNU6ES08600 GGAM-DNU6ES00600 GGAM-DNU6ES01600 GGAM-DNU6ES02600 GGAM-DNU6ES03600 GGAM-DNU6ES04600 GGAM-DNU6ES05600 GGAM-DNU6EF05600 GGAM-DNU6EF06600 GGAM-DNU6EF07600	GGAM-DNU6EF08600
		AT	No	39110-2BCG5 39110-2BCG2 39110-2BCC1	GGAM-BNU6PS00C00 GGAM-BNU6PS01C00 GGAM-BNU6PS02C00 GGAM-BNU6PS03C00 GGAM-BNU6PS04C00 GGAM-BNU6PS05C00 GGAM-BNU6PS06C00 GGAM-BNU6PS07C00 GGAM-BNU6PS08C00 GGAM-DNU6PS00C00 GGAM-DNU6PS01C00 GGAM-DNU6PS02C00 GGAM-DNU6PS03C00 GGAM-DNU6PS04C00 GGAM-DNU6PS05C00 GGAM-DNU6PS06C00 GGAM-DNU6PS07C00 GGAM-DNU6PF07C00 GGAM-DNU6PF08C00 GGAM-DNU6PF09C00	GGAM-DNU6PF0AC00
				39110-2BCG8 39110-2BCG3 39110-2BCE1	GIAM-BNU6PS00C00 GIAM-BNU6PS01C00 GIAM-BNU6PS02C00 GIAM-BNU6PS03C00 GIAM-BNU6PS04C00 GIAM-BNU6PS05C00 GIAM-BNU6PS06C00 GIAM-BNU6PS07C00 GIAM-BNU6PS08C00 GIAM-DNU6PS00C00 GIAM-DNU6PS01C00 GIAM-DNU6PS02C00 GIAM-DNU6PS03C00 GIAM-DNU6PF03C00 GIAM-DNU6PF04C00	GIAM-DNU6PF05C00

Model	EM	TM	IMMO	ECU P/No.	ECU ROM ID	
					Previous	New
14MY Soul (PS)	1.6 ULEV	MT	No	39110-2BSH0	GGPS-DNU6ES00600 GGPS-DNU6ES01600 GGPS-DNU6EF01600 GGPS-DNU6EF02600 GGPS-DNU6EF03600	GGPS-DNU6EF04600
		AT	No	39110-2BSH5	GGPS-DNU6PS00C00 GGPS-DNU6PS01C00 GGPS-DNU6PF01C00 GGPS-DNU6PF02C00 GGPS-DNU6PF03C00	GGPS-DNU6PF04C00
15MY Soul (PS)	1.6 ULEV	MT	No	39110-2BSH1	GGPS-FNU6ES00600 GGPS-FNU6ES01600 GGPS-FNU6ES02600 GGPS-FNU6EF02600 GGPS-FNU6EF03600	GGPS-FNU6EF04600
		AT	No	39110-2BSH6 39110-2BSH7	GGPS-FNU6PS00C00 GGPS-FNU6PS01C00 GGPS-FNU6PS02C00 GGPS-FNU6PF02C00 GGPS-FNU6PF03C00	GGPS-FNU6PF04C00
16MY Soul (PS)	1.6 ULEV	MT	No	39110-2BSG3	GGPS-GNU6ES00600 GGPS-GNU6ES01600 GGPS-GNU6EF01600	GGPS-GNU6EF02600
		AT	No	39110-2BSE8	GGPS-GNU6PS00C00 GGPS-GNU6PS01C00 GGPS-GNU6PF01C00	GGPS-GNU6PF02C00

To verify the vehicle is affected, be sure to check the Calibration Identification of the vehicle's ECM ROM ID and reference the Information Table as necessary.

★ NOTICE

Prior to performing the ECU upgrade, be sure to check that the KDS is fully charged.

1. Connect the VCI-II to the OBD-II connector, located under the driver's side of the instrument panel.

★ NOTICE

The ECU upgrade function on KDS operates wirelessly. It is not necessary to perform the upgrade via USB cable.



SUBJECT: ENGINE CONTROL UNIT (ECU) LOGIC IMPROVEMENT (SC176)

2. With the ignition ON, turn ON the KDS tablet. Select **KDS** from the home screen.



3. Confirm communication with VCI (A) and then configure the vehicle (B) using the **AUTO VIN** (C) feature.

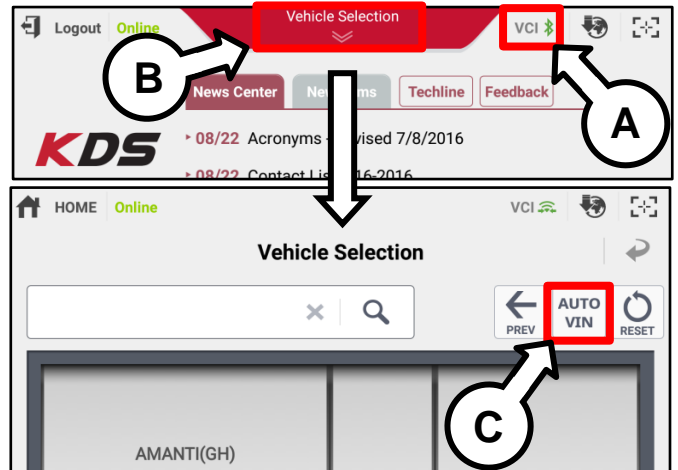

4. Select **ECU Upgrade**.

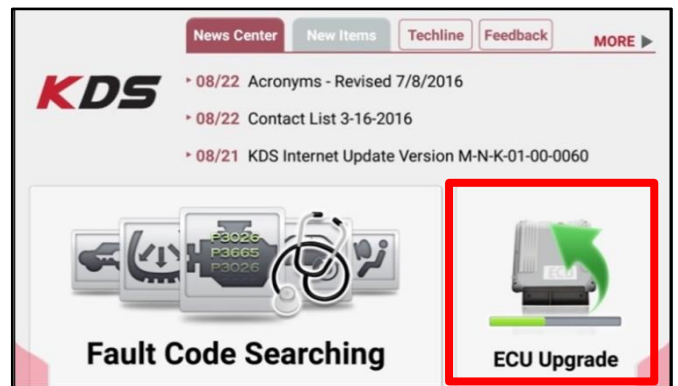

5. The KDS will check the server for recently uploaded Events and then automatically download **Upgrade Event #412(PS)** or **#413(AM)**.

*** NOTICE**
 The vehicle must be identified in Vehicle Selection to download an Event for that vehicle.

After the download is complete, the program will shut down to install. Please wait until the program restarts.

Event	Status
271.QF 2.4GDI DTC P0171,P0420 LOGIC IMPROVEMENT	Downloading
273.TF 2.4GDI DTC P0171,P0420 LOGIC IMPROVEMENT	Ready

36%

Do not touch any system buttons while performing this function.

KDS screenshot shown above is for demonstration purposes only. Events shown in screenshot are not applicable to this bulletin.

6. Select **Auto Mode**.

CAUTION

Do NOT attempt to perform a Manual Mode upgrade UNLESS Auto Mode fails. Always follow the instructions given on the KDS in either Auto or Manual mode.

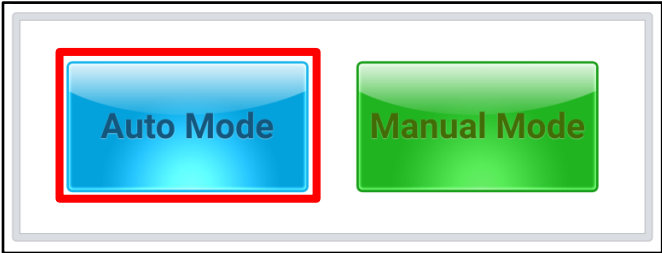

7. Select the **Engine** system under the System selection menu.

Touch **ID Check** (D) and confirm that the latest update is available.

Select **Upgrade Event #412(PS)** or **#413(AM)** and select **Upgrade** to continue.

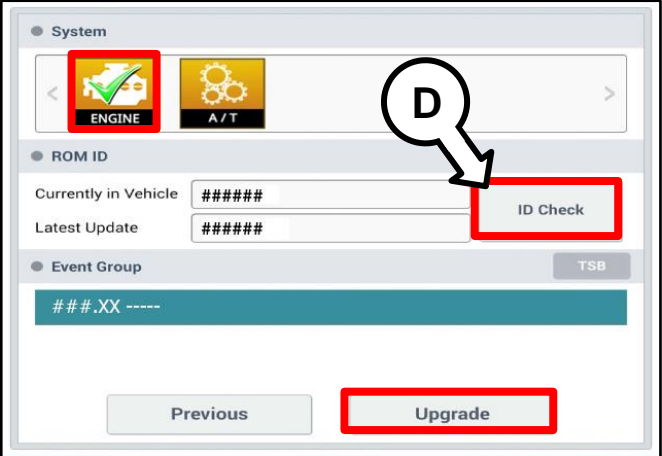

8. The ECU upgrade will begin and the progress of the upgrade will appear on the bar graph. Upgrade part (1/2) (E) will download the upgrade event to the VCI-II. Upgrade part (2/2) (F) will upgrade the ECU.

CAUTION

Do not touch the system buttons (like 'Back', 'Home', 'etc.') while performing ECU Upgrade.

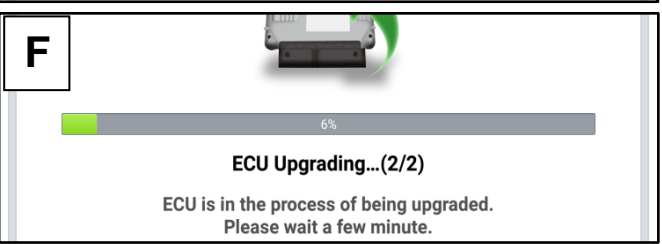
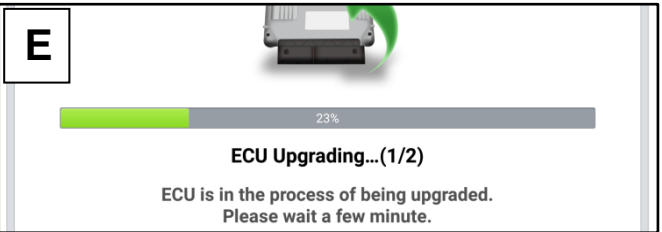

9. If a "Communication Fail" screen appears, verify that the VCI-II and KDS are communicating properly. Touch **OK** and restart the procedure from step 4.

*** NOTICE**

If an error notice continues to appear or if the upgrade cannot be performed, DO NOT disconnect the KDS/VCI-II. Contact GIT America Help Desk at (888) 542-4371 or Techline.

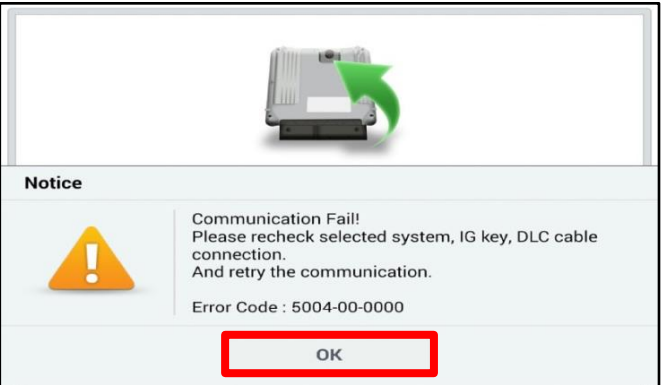

SUBJECT: ENGINE CONTROL UNIT (ECU) LOGIC IMPROVEMENT (SC176)

10. When instructed on the KDS, turn the ignition **OFF** for ten (10) seconds then back on. Touch **OK** to continue.

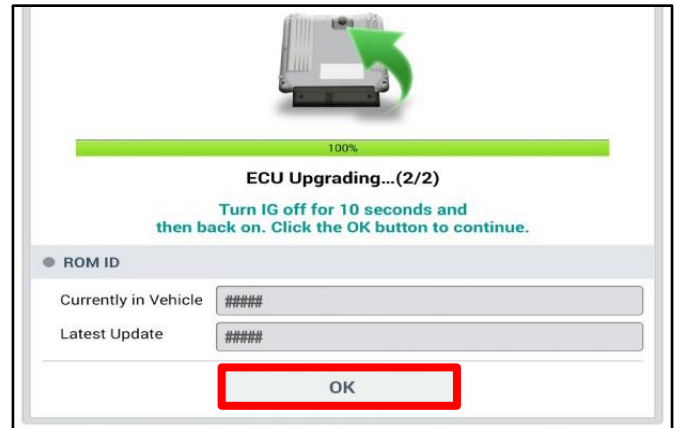

11. Once the upgrade is complete, touch **OK** to finalize the procedure.

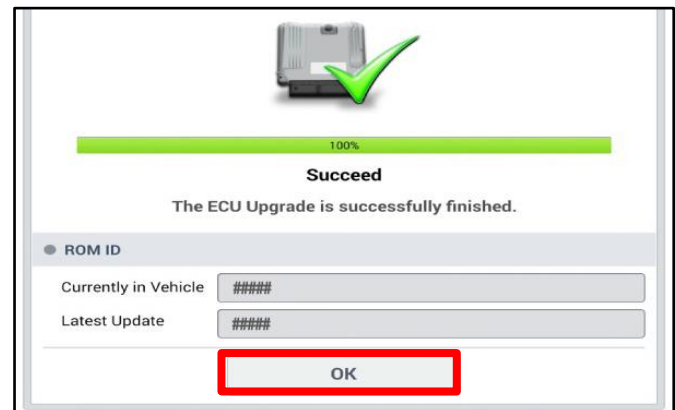

12. When prompted, select **YES** to check for Diagnostic Trouble Codes (DTC) and erase any DTCs stored such as EPS, ESC, and TPMS that may have been set during the upgrade.

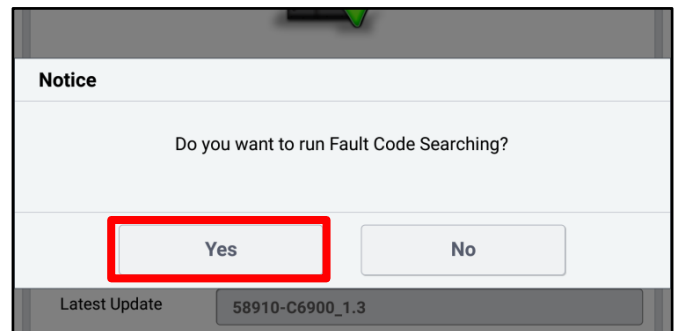

13. Start the engine to confirm proper operation of the vehicle.

Manual Upgrade Procedure:*** NOTICE**

The manual upgrade should **ONLY** be performed if the automatic upgrade fails.

If the automatic upgrade fails, turn the ignition **OFF** for about **10 seconds** then place it back in the **ON** position to reset the control unit **BEFORE** performing manual upgrade.

See table below for Manual Mode passwords.

Manual Mode ECU Upgrade Passwords

Model	Menu	Password
Soul (AM)	AM GAMMA 1.6GDI ULEV 12~13MY MT -IMMO NON ISG : 39110-2BCG0/J0	1020
	AM GAMMA 1.6GDI ULEV 12~13MY AT -IMMO NON ISG : 39110-2BCG5/G2/C1	1022
	AM GAMMA 1.6GDI ULEV 12~13MY AT -IMMO ISG : 39110-2BCG8/G3/E1	1024
Soul (PS)	PS GAMMA 1.6GDI ULEV 14MY MT -IMMO NON ISG : 39110-2BSH0	1020
	PS GAMMA 1.6GDI ULEV 14MY AT -IMMO NON ISG : 39110-2BSH5	1025
	PS GAMMA 1.6GDI ULEV 15MY MT -IMMO NON ISG : 39110-2BSH1	1022
	PS GAMMA 1.6GDI ULEV 15MY AT -IMMO NON ISG : 39110-2BSH7/H6	1027
	PS GAMMA 1.6GDI ULEV 16MY MT -IMMO NON ISG : 39110-2BSG3	1023
	PS GAMMA 1.6GDI ULEV 16MY AT -IMMO NON ISG : 39110-2BSE8	1030

1. Within the ECU Upgrade screen displayed, select **Manual Mode**.
2. Select the **Engine** system under the System selection menu. Select **Upgrade Event #412(PS) or #413(AM)** and select **Upgrade** to continue.
3. Select the appropriate control unit part number with reference to the ROM ID Information Table on pages 3-4 and select **OK**.
4. Enter the appropriate password from the Manual Mode password table above and select **OK**.
5. The upgrade will begin and the progress of the upgrade will appear on the bar graph.
6. When instructed on the KDS, turn the ignition **OFF** for ten (10) seconds then back on. Touch **OK** to continue.
7. Once the upgrade is complete, touch **OK** to finalize the procedure.
8. When prompted, select **YES** to check for Diagnostic Trouble Codes (DTC) and erase any DTCs stored such as EPS, ESC, and TPMS that may have been set during the upgrade.
9. Start the engine to confirm proper operation of the vehicle.

Engine Compression Check Procedure: P0420 “stored” & P030X “Active”

1. Ensure all conditions are met and then perform an engine compression check by referring to the “Engine Mechanical System → Compression Test” chapter in the applicable Shop Manual on KGIS.

Conditions:

- Coolant at operating temp (176°F)
- Battery fully charged
- If all cylinder compression results* are above the minimum specification, proceed to the Catalytic Converter Assembly Replacement Procedure below.
- If any cylinder compression result* is below the minimum specification, proceed to the Short Block Assembly Replacement Procedure on page 10.

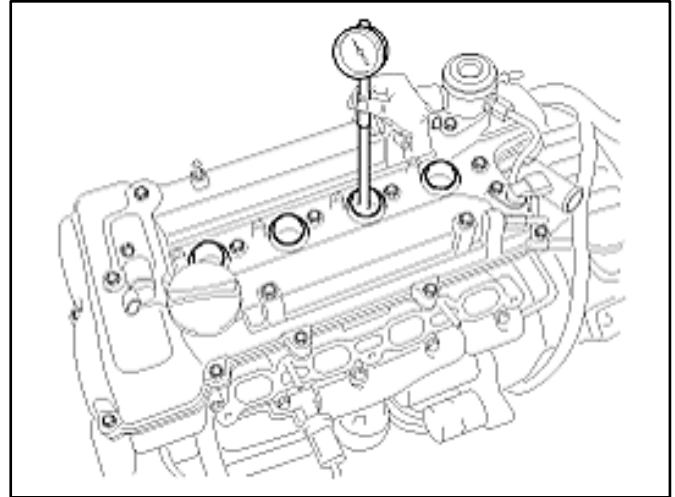
**Compression Specifications**

Standard	178 PSI, 1225.83 KPa, 12.5 kg.cm ²
Minimum	149 PSI, 1029.69 KPa, 10.5 kg.cm ²

***Perform all cylinder compression checks twice (2x) and record both peak cranking values clearly and legibly on the repair order.**

**Tightening torque for spark plugs:
10.8 – 17.0 lb.ft (14.7 – 24.5 N.m,
1.5 – 2.5 kgf.m)**

Catalytic Converter Assembly Replacement Procedure:

1. Record or retain the customer’s radio presets using the Memory Saver and then disconnect the negative (-) battery terminal.
2. Replace the catalytic converter assembly by referring to the “Engine Mechanical System → Intake and Exhaust System → Exhaust Manifold → Repair procedures” chapter in the applicable Shop Manual on KGIS.

*** NOTICE**

Be sure to transfer the O2 sensor and replace the exhaust manifold and front pipe gaskets.

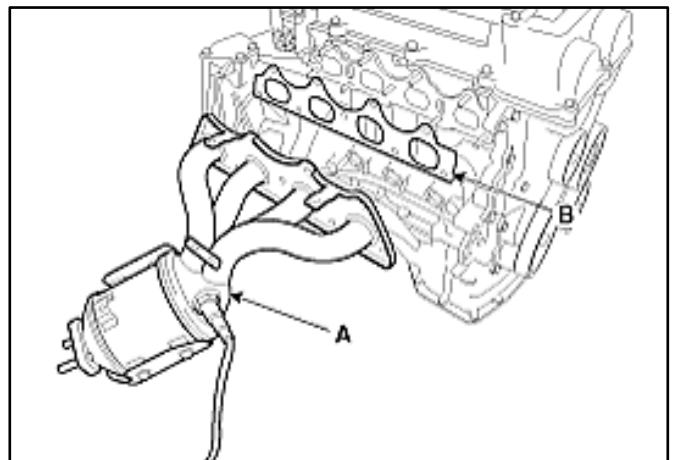

3. Reconnect the negative (-) battery terminal. Verify customer’s radio presets were retained and restore, if necessary, using recorded information in step 1 of the Inspection Procedure.
4. Perform the ECU Logic Improvement Procedure on page 2.

Short Block Replacement Procedure: P0420 “stored” & P030X “Active”

1. Record or retain the customer’s radio presets using a Memory Saver.
2. Remove the engine by referring to the “Engine Mechanical System → Engine And Transaxle Assembly → Engine And Transaxle Assembly → Repair procedures” chapter in the applicable Shop Manual on KGIS.

Refer to [TSB ENG190](#) for information regarding engine replacement practices.

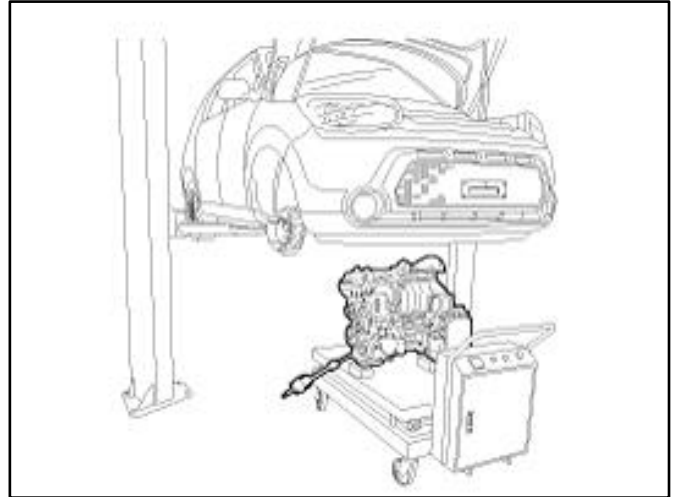

3. Remove the cylinder head by referring to the “Engine Mechanical System → Cylinder Head Assembly → Cylinder Head → Repair procedures” chapter in the applicable Shop Manual on KGIS.

*** NOTICE**

Some Shop Manual instructions regarding the removal of certain components during the removal of the engine may be repeated in the removal of the cylinder head.

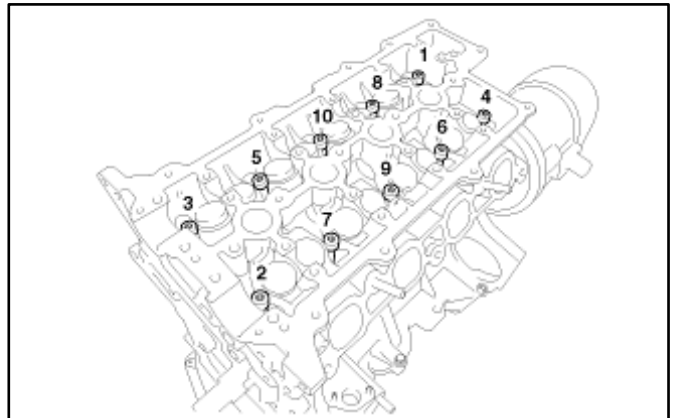

4. Place the new engine short block on an engine stand.
5. Install all removed components from the old engine block onto the new engine block utilizing all parts from the Short Block Service Kit. Be advised of notes below.

Notes:**Cylinder Head**

- Use a new cylinder head gasket.
- Be sure to replace the cylinder head bolts and washers and torque them in the sequence shown.

Tightening torque of head bolts:
21.7 lb.ft (29.4 N.m, 3.0 kgf.m) + 90° + 90° (180° degrees total)

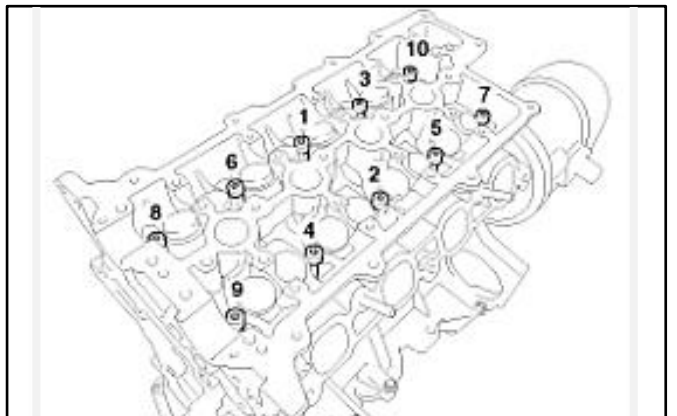

SUBJECT: ENGINE CONTROL UNIT (ECU) LOGIC IMPROVEMENT (SC176)
Valve Cover

- Use a new valve cover gasket.
- Be sure to torque the valve cover bolts in the sequence shown.

Tightening torque of valve cover:

Step 1: 2.9 – 4.3 lb.ft (3.9 – 5.9 N.m, 0.4 – 0.6 kgf.m)

Step 2: 5.8 – 7.2 lb.ft (7.8 – 9.8 N.m, 0.8 – 1.0 kgf.m)

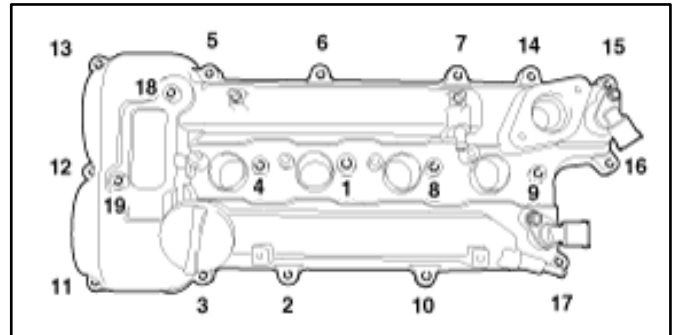
High Pressure Pump & Roller Tappet:

- Refer to [TSB ENG083](#) for special attention and handling procedures of GDI-specific components.
- When installing the high pressure pump and roller tappet onto the new engine, apply engine oil to the roller tappet and O-rings of the high pressure pump.

Tightening torques of pump bolts:

9.4 – 10.9 lb.ft (12.8 – 14.7 N.m, 1.3 – 1.5 kgf.m)

Tightening torques of pipe flare nuts:

19.5 – 23.9 lb.ft (26.5 – 32.4 N.m, 2.7 – 3.3 kgf.m)

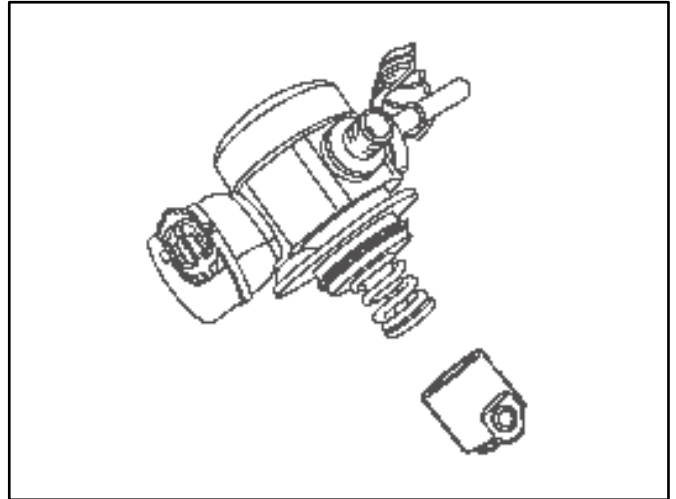
*** NOTICE**

Refer to [TSB ENG083](#) for gasoline direct injection (GDI) specific information, including related warnings and cautions for handling high fuel pressure system components.

High Pressure Fuel Pipe:

1. Properly position the new fuel pipe (A) and then hand-tighten both flare nuts (B).

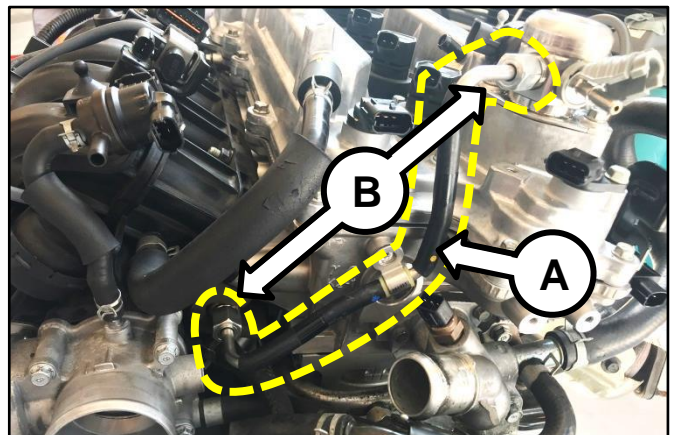

2. Install the pipe retaining bracket and bolts (C) and torque to specifications.

Tightening torque (bracket bolts):
 5.8 – 8.7 lb.ft (7.8 – 11.8 N.m,
 0.8 – 1.2 kgf.m)

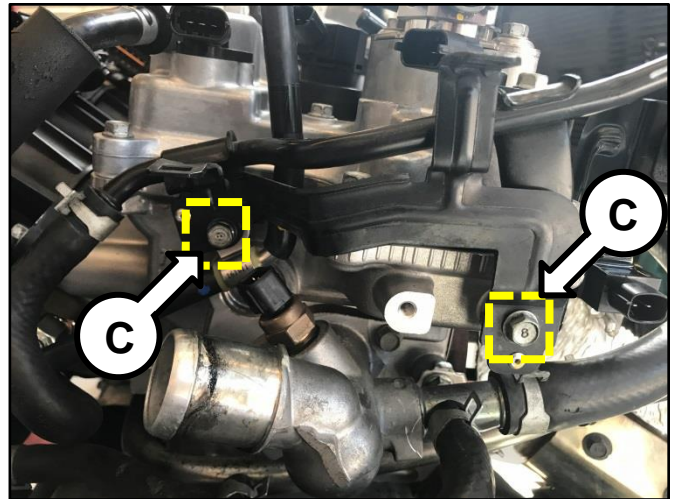

3. Using a click-type/electronic torque wrench and SST 09314-3Q100, torque both flare nuts (B) to specifications.

Tightening torque (flare nuts):
 19.5 – 23.9 lb.ft (26.5 – 32.4 N.m,
 2.7 – 3.3 kgf.m)

[*Click here to see a video tutorial of high pressure fuel pipe install \(includes high pressure pump install\).](#)

*The engine used in the video tutorial is a 2.0L Theta engine and is used for demonstration purposes only.

★ IMPORTANT

The high pressure fuel pipe bracket and bolts must be installed and properly torqued prior to torquing the high pressure fuel pipe flare nuts.

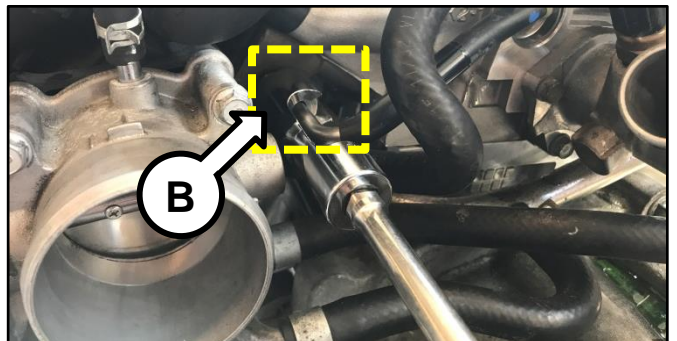
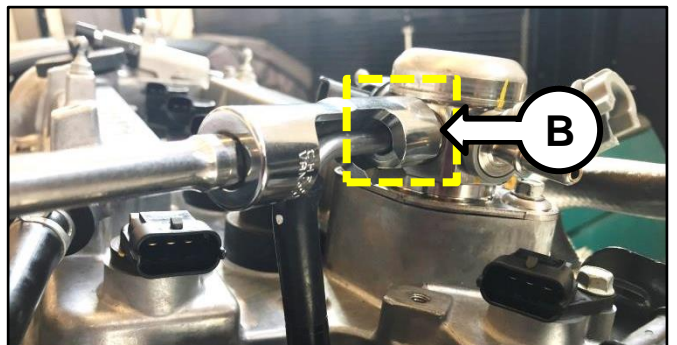

Intake Manifold:

- Prior to installation, replace the intake manifold gasket.
- Torque bolts in the sequence shown.

Tightening torque of bolts:
 13.7 – 17.4 lb.ft (18.6 – 23.5 N.m,
 1.9 – 2.4 kgf.m)

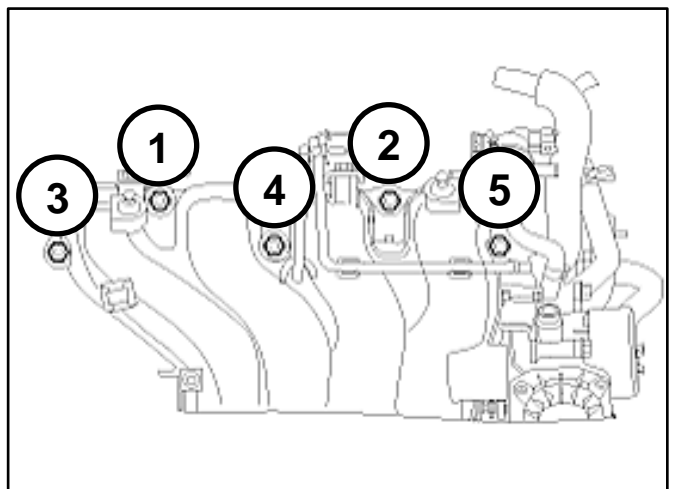

SUBJECT: ENGINE CONTROL UNIT (ECU) LOGIC IMPROVEMENT (SC176)
Exhaust Manifold:

- Prior to installation, replace the exhaust manifold and front pipe gaskets.
- Torque nuts in the sequence shown.
- Replace the exhaust front pipe nuts.

Tightening torque of nuts:

**36.2 – 39.7 lb.ft (49.0 – 53.9 N.m,
5.0 – 5.5 kgf.m)**

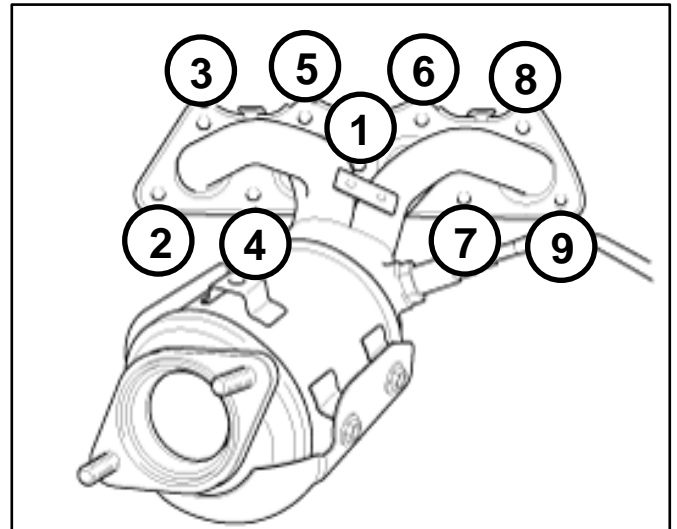





6. Verify proper operation of the vehicle with road test and erase any stored DTCs (e.g. EPS, ESC, and TPMS) that may have been set by this procedure. Verify no leaks exist and ensure engine oil and coolant are at their proper level.
If any DTCs are still active, follow any related diagnosis and repair as needed.
7. Verify customer's radio presets were retained and restore, if necessary, using recorded information in step 1 of the Inspection Procedure.

SUBJECT: ENGINE CONTROL UNIT (ECU) LOGIC IMPROVEMENT (SC176)

AFFECTED VEHICLE RANGE:

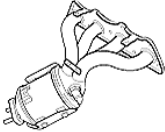
Model	Production Date Range
Soul (AM, PS)	July 8, 2011 through August 11, 2016

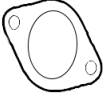
REQUIRED PART:

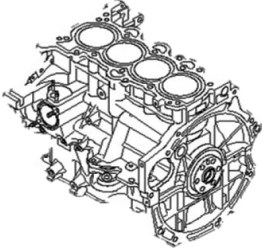
Part Name	Part Number	Figure	Comment
Catalytic Converter Assembly	28510 2BEF1QQK		-
Exhaust Manifold Gasket	28521 2B400		DTC P0420 must Be stored prior to replacement of the catalytic converter. For replacement of catalytic converter only (Do not order if replacing short block)
Exhaust Front Pipe Gasket	28751 3S000		
Exhaust Front Pipe Nuts (2) (AM) only	28679 21000		
Exhaust Front Pipe Nuts (2) (PS) only	13183 12000		
Short Block Assembly	36ZG2 2BX00QQK (Non-ISG)		DTCs P0420 (Active, Pending or History) and P030X (Active) must be stored prior to replacement of Short Block
	205X2 2BH00QQK (ISG)		
Short Block Assembly Service Kit	21110 2BH00QQK	-	<u>Includes:</u> 1 Valve Cover Gasket 1 OCV Adapter Gasket 1 Exhaust Manifold Gasket 1 Intake Manifold Gasket 1 Cylinder Head Gasket 10 Cylinder Head Bolts 10 Cylinder Head Washers 1 High Press. Pump O-Ring 1 High Press. Fuel Pipe 2 High Press. Pump Bolts 1 Exhaust Pipe Gasket 2 Exhaust Pipe Nuts 1 Oil Strainer Gasket 1 Heater Pipe O-Ring 1 Oil Pump O-Ring 1 Water Pump Gasket

Note: Part Number 204X2 2BH00QQK (Non-ISG) has been superseded by part number 36ZG2 2BX00QQK (Non-ISG).

SUBJECT: ENGINE CONTROL UNIT (ECU) LOGIC IMPROVEMENT (SC176)

WARRANTY INFORMATION:

N Code: N99 C Code: C99

Model	Claim Type	Causal P/N	Qty.	Repair Description	Labor Op Code	Op Time	Replacement P/N	Qty.
AM 12-13MY	R	39110 2BCG5	0	(SC176) ECU Logic Improvement Only	191025R0	0.3 M/H	N/A	0
				(SC176) Cat Converter Replacement & ECU Logic Improvement	191025R1 DTC Required	1.4 M/H	28510 2BEF1QQK	1
							28521 2B400	1
							28751 3S000	1
							28679 21000	2
				(SC176) Engine Compression Check, Cat Converter Replacement, & ECU Logic Improvement	191025R2 DTCs Required	1.9 M/H	28510 2BEF1QQK	1
							28521 2B400	1
							28751 3S000	1
							28679 21000	2
				(SC176) Engine Compression Check, Short Block Replacement, Cat Converter Replacement, & ECU Logic Improvement	191025R3 DTCs Required	10.5 M/H	28510 2BEF1QQK	1
							36ZG2 2BX00QQK (Non-ISG)	1
							205X2 2BH00QQK (ISG)	
21110 2BH00QQK	1							
PS 14-16MY	R	39110 2BSH5	0	(SC176) ECU Logic Improvement Only	191026R0	0.3 M/H	N/A	0
				(SC176) Cat Converter Replacement & ECU Logic Improvement	191026R1 DTC Required	1.4 M/H	28510 2BEF1QQK	1
							28521 2B400	1
							28751 3S000	1
							13183 12000	2
				(SC176) Engine Compression Check, Cat Converter Replacement, & ECU Logic Improvement	191026R2 DTCs Required	1.9 M/H	28510 2BEF1QQK	1
							28521 2B400	1
							28751 3S000	1
							13183 12000	2
				(SC176) Engine Compression Check, Short Block Replacement, Cat Converter Replacement, & ECU Logic Improvement	191026R3 DTCs Required	10.5 M/H	28510 2BEF1QQK	1
							36ZG2 2BX00QQK (Non-ISG)	1
							21110 2BH00QQK	1

Notes: Use sublet code 'X1' with a maximum allowed amount of \$2.00 for liquid sealant. Use sublet code 'X3' with a maximum allowed amount of \$29.80 for engine oil & coolant. If necessary, please use sublet code 'RX' for rental expense reimbursement which will create a separate 'N' claim (example, submitting campaign repair claim '12345 A' with rental sublet 'RX' will create a separate rental claim '12345 N'). For any related vehicle concerns after the campaign is closed, utilize the normal service parts and procedures. There may be a mandatory parts return request for parts associated with this campaign repair when the catalytic converter and/or engine is replaced.

*** NOTICE**

VIN inquiry data for this repair is provided for tracking purposes only. Kia retailers should reference **SC176** when accessing the KDealer+ system.